

Becosolar Datasheet



Solar Shunt Regulator

BR1/12/6

- Low power consumption
- Fully encapsulated
- Stainless steel heatsink / mounting plate
- Rated to 6A
- 12V Nominal Voltage
- Temperature compensated
- Status indication (shunt)
- Solid state
- Small & simple to fit
- Low cost
- Safely paralleled
- Blocking diode included

Functional Description

The BR1 is a shunt regulator designed to limit the maximum voltage to which a lead acid battery can be driven when on charge from a photovoltaic (solar) module or array. It is a simple, low cost, solid state device for use with photovoltaic modules having a peak current not exceeding 6A. The unit has very low power consumption and features a single green, status indicating LED, which is illuminated when the battery voltage has reached the set-point and the module output is being shunted.

The circuit for the regulator (shown in the diagram opposite.) comprise three main elements, a voltage comparator, a semiconductor switch and a blocking diode. The purpose of these elements is as follows:

Voltage Comparator

The battery voltage is constantly compared with an internal reference level and when it reaches the set-point the semiconductor switch is triggered. The reference set-point voltage is automatically adjusted upwards at lower temperatures and downwards at higher ones.

Semiconductor Switch

When triggered the switch shunts the solar module/array, diverting its output away from the battery. When the battery voltage has decayed by 1.3V the module/array output is reconnected to the battery.

Blocking Diode

This is an electronic non-return valve and serves two purposes. Firstly it ensures the battery cannot discharge through the module/array at night and secondly that the battery is not shorted when the regulator shunts the module/array.

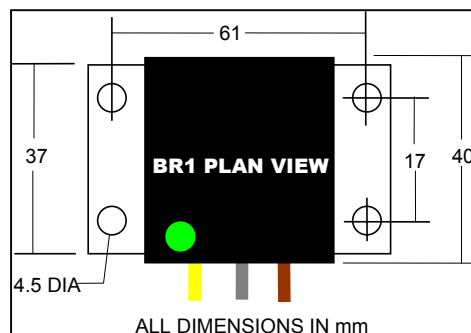
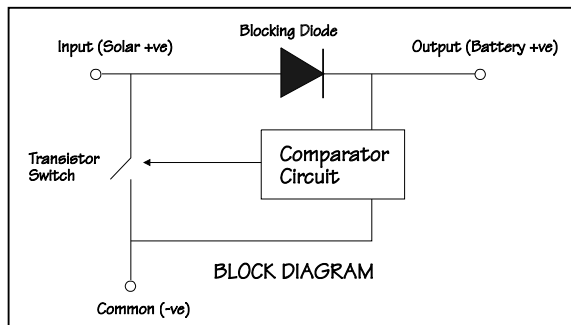

Detailed Description

- 1) The regulator's PCB is encapsulated in polyurethane within a black ABS box measuring 40(L) x 40 (W) x 20 (H). This assembly is fastened to a 1mm thick stainless steel heatsink measuring 71 (L) x 37 (W).
- 2) The heat sink also enables the unit to be easily mounted via four 4.5mm DIA holes.
- 3) The unit is rated at 6A and will easily handle the output from one MSX-83 module.
- 4) The shunt set-point is fixed at 14.6V (nom 12V) with reconnection at 13.2V
- 5) The ends of the three 120mm leads (SOLAR POS, BATTERY POS and COMMON NEG) are paired back for testing and can be terminated with a variety of connectors or left bare to suit the user.

Colour Code - SOLAR +ve	YELLOW
COMMON -ve	GREY
BATTERY +ve	BROWN
Nominal Voltage (V)	12V
Shunt Set-Point (V)	14.5
Reconnect Voltage (V)	13.2
Diode Voltage Drop (V)	0.4
Temperature Coeff. of Voltage (mV/°C)	-10
Input Current (max) (A)	6
Typical Consumption (mA)	<5

Specifications subject to change without notice



Beco Limited, 1, 2 & 3 The Alpha Centre, Babbage Road, Totnes, Devon, TQ9 5JA
 t. 01803 833636 | f. 01803 862829 | e. sales@becosolar.com | www.becosolar.com