

80 Watt Photovoltaic Module

BP 380

The BP 380 is an advanced 80W photovoltaic module utilising polycrystalline cells with anti-reflective SiN coating. This solar module is as equally suited to grid connect applications, such as residential systems or installations on commercial roofs, as traditional photovoltaic applications such as telecommunications and rural electrification. This 36 cell module offers a superior price – performance relationship with a white polyester back sheet and innovative, high-efficiency cells.

Performance	BP 380	BP 375
Rated power	80W	75W
Power tolerance	5%	5%
Nominal voltage	12V	12V
Warranty	90% of minimum warranted power output over 12 years 80% of minimum warranted power output over 25 years Free from defects in materials and workmanship for 5 years	

Configuration

BP 380S	Universal frame, a sealed junction box with output cables and polarised Multicontact (MC) connectors
BP 380L	Unframed version of the BP 380S
BP 380J	Universal frame with an accessible junction box for cable connection

Qualification Test Parameters

Temperature cycling range	-40°C to +85°C
Damp heat test	85°C and 85% relative humidity
Front & rear static load test (eg: wind)	2400 Pa
Front load test (eg: snow)	5400 Pa
Hailstone impact test	25mm hail at 23m/s

Quality and Safety

- Manufactured in ISO 9001 and ISO 14003 certified factories
- Conforms to European Community Directive 89/33/EEC, 73/23/EEC, 93/68/EEC
- Certified to IEC 61215

Module power measurements calibrated to World Radiometric Reference through ESTI (European Solar Test Installation at Ispra, Italy)

Framed modules certified by TÜV Rheinland as Safety Class II (IEC 60364) equipment for use in systems up to 1000 VDC

Framed modules listed by Underwriter's Laboratories for electrical and fire safety (Class C fire rating)

Laminates recognised by Underwriter's Laboratories for electrical and fire safety (Class C fire rating)

Approved by Factory Mutual Research in NEC Class 1, Division 2, Groups C & D hazardous locations (BP ####J)

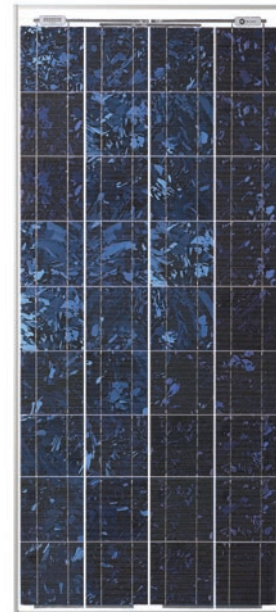

BP 380

BP 380 I-V Curves

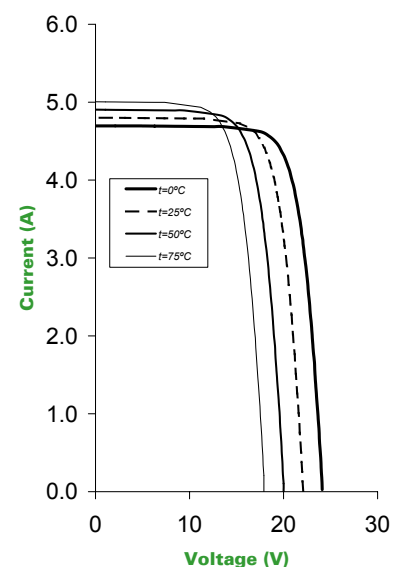

80 Watt Photovoltaic Module BP 380

Module Diagram

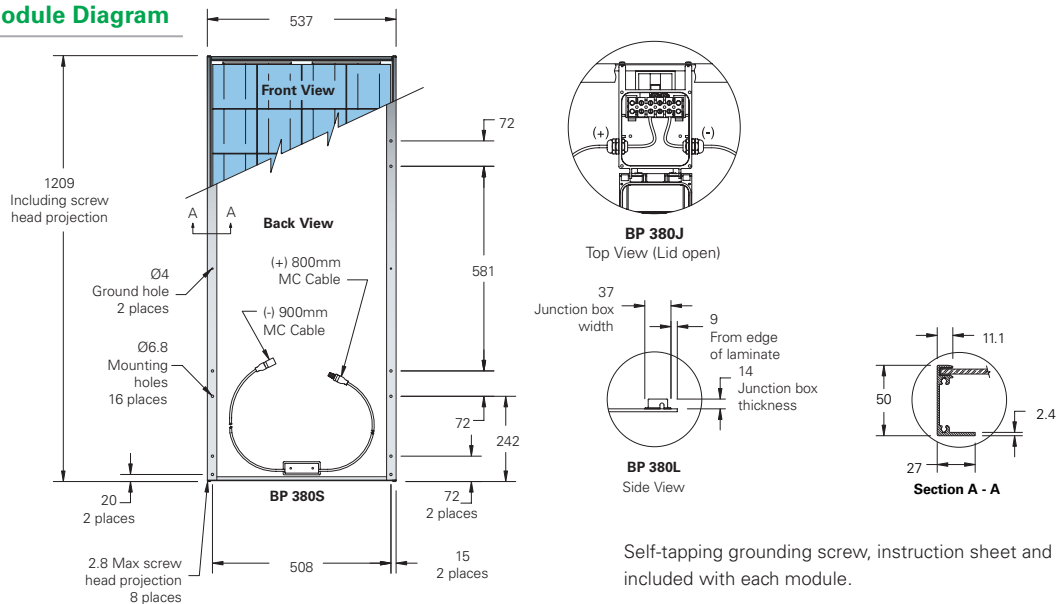

Typical Electrical Characteristics

	BP 380	BP 375 ³
Rated Power (P_{max}) ¹	80W	75W
Warranted minimum power	76W	71W
Voltage at P_{max} (V_{mp})	17.6V	17.3V
Current at P_{max} (I_{mp})	4.55A	4.35A
Short circuit current (I_{sc})	4.8A	4.75A
Open circuit voltage (V_{oc})	22.1V	21.8V
Temperature coefficient of I_{sc}	(0.065±0.015)%/°C	
Temperature coefficient of V_{oc}	-(80±10)mV/°C	
Temperature coefficient of P_{max}	-(0.5±0.05)%/°C	
NOCT ²	47±2°C	
Maximum series fuse rating	15A (BP 380S) / 20A (BP 380J)	
Maximum system voltage	600V (IEC 61215 rating) 1000V (TÜV Rheinland rating)	

Mechanical Characteristics

	BP 380S / BP 380J ⁴	BP 380L
Dimensions (mm) (Overall tolerances +/-3mm)	1209 x 537 x 50	1197 x 530 x 19
Weight (kg)	7.7	6.1
Frame	Clear anodised aluminium alloy type 6063T6. Colour: silver.	
Solar cells	36 cells (125mm x 125mm) configured geometrically for a 9 x 4 matrix connected in series.	
Output cables (BP 380S)	RHW AWG# 12 (4mm ²) cable with polarised weatherproof DC rated Multicontact (MC) connectors; asymmetrical lengths 900 (-) and 800mm (+).	
Junction box (BP 380J)	IP65 junction box with 4 terminal screw connection block, accepts PG 13.5, M20, 13mm conduit, or cable fittings accepting 6 – 12mm diameter cable. Terminals accept 2.5 – 10mm ² (8 to 14 AWG) wire.	
Diodes	Two 9A, 45V Schottky by-pass diodes included.	
Construction	Front: High transmission 3mm tempered glass Rear: White polyester; Encapsulant: EVA.	

1. Standard test conditions (STC), irradiance of 1000W/m² at an AM1.5G solar spectrum and a cell temperature of 25°C.

2. Normal Operating Cell Temperature (NOCT), air temperature of 20°C; irradiance 800W/m²; wind speed 1m/s.

3. Power of solar cells varies in the normal course of production; the BP 375 is assembled using cells of slightly lower power than the BP 380.

4. The mechanical characteristics of the BP 375 and BP 380 are identical.

Your BP Solar Distributor:



**1 - 3 The Alpha Centre,
Babbage,
Totnes,
Devon,
TQ9 5JA**

**t. 01803 866329
f. 01803 862824
e. info@becosolar.com
w. www.becosolar.com**